

MIGHTY EX10 – EURO 6 SUPER CAB



*Actual vehicle may differ from above image

4 x 2 Super Cab Chassis

KEY FEATURES

KEY SPECIFICATIONS

| | | |
|--|-------------------------|-------------------------------------|
| Vehicle Dynamic Control (VDC) | GVM | 10,300kg |
| Autonomous Emergency Braking System (AEBS) | GCM | 11,500kg |
| Driver's Suspension Seat | Engine | 3.9L Diesel 4 Cylinder Turbo Euro 6 |
| ADR 80/04 (Euro VI) Compliant | Power | 170ps/125kW |
| Lane Departure Warning System (LDWS) | Torque | 608Nm |
| Full Air Brakes | Transmission | 6 speed Manual / 8 speed Automatic |
| SRS Airbags Driver & Passenger | Wheelbase | MWB 3.6m, LWB 4.05m, ELWB 4.4m |
| Cruise Control | Max. Body Length | MWB 4.6m, LWB 5.3m, ELWB 6.0m |

ENGINE

| | |
|---------------------|-------------------------------------|
| Engine Model | Hyundai D4GB17 |
| Engine Type | Diesel 3.9L Inline 4 Cylinder Turbo |
| Max. Output | 170ps@2,500rpm |
| Max. Torque | 608Nm@1,400rpm |
| Emission Level | ADR 80/04 - Euro VI |
| Fuel Injection | Electrical type by ECU |
| Cooling System | Water cooling type with thermostat |
| Compression Ratio | 17.1: 1 |
| Piston Displacement | 3,933 cc |
| Bore and Stroke | 103 x 118 (mm) |
| Valve System | SOHC, 4 valves per cylinder |
| Exhaust | Catalytic Converter DOC/DPF/SCR |
| Alternator | 24V-55A |
| Engine Immobilizer | Equipped |



TRANSMISSION & GEAR RATIOS

| Model & Description | Manual Transmission (T060S6) | | Automatic Transmission (ZF8AP800) | |
|---------------------|------------------------------|-------|-----------------------------------|-------|
| | 6 Speed Manual | | 8 Speed Automatic | |
| Gear Ratios | 1 | 6.701 | 1 | 4.890 |
| | 2 | 3.712 | 2 | 3.123 |
| | 3 | 2.084 | 3 | 2.033 |
| | 4 | 1.351 | 4 | 1.639 |
| | 5 | 1.000 | 5 | 1.254 |
| | 6 | 0.732 | 6 | 1.000 |
| | 7 | N/A | 7 | 0.840 |
| | 8 | N/A | 8 | 0.639 |
| | REVERSE | 5.983 | REVERSE | 4.25 |
| Gear Shaft | Floor Shift | | Mechanical Remote Control | |
| Rear Axle Ratio | 4.625 | | 4.111 | |

BRAKES

| | |
|--|---|
| Type | 4 wheel Drum Brakes |
| Actuation | Full Air + ABS + ASR |
| Front Drum Diameter | 325mm |
| Rear Drum Diameter | 325mm |
| Adjuster | Installed |
| Vehicle Stability Control (VSC) | Equipped |
| Parking Brake | Full air, dual circuit fixed S CAM with spiring loaded chambers |
| Anti-lock Brake System (ABS) | Equipped |
| Electronic Braking System (EBS) | Equipped |
| Autonomous Emergency Braking System (AEBS) | Equipped |

POWER AND TORQUE CHART

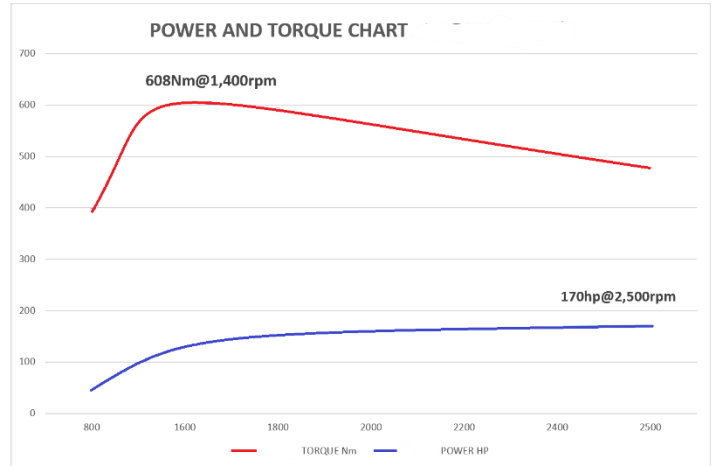

SAFETY FEATURES

| | |
|-------------------------------------|--------------------|
| Vehicle Dynamic Control | VDC (Equipped) |
| Electronic Stability Control | ESC (Equipped) |
| Anti-lock Brake System | ABS (Equipped) |
| Traction Control System | TCS (Equipped) |
| Lane Departure Warning System | LDWS (Equipped) |
| SRS Airbag | Driver & Passenger |
| Autonomous Emergency Braking System | AEBS (Equipped) |
| Cruise Control | CC (Equipped) |
| Driver's Suspension Seat | Equipped |

SUSPENSION & LOAD LIMITS

| | | |
|------------------------|-----------------------------|------------------|
| Front Axle Type | Reverse Eliot Type "I" Beam | |
| Front Axle Capacity | 3,700 kg | |
| Rear Axle Type | Full Floating Type | |
| Rear Axle Capacity | 6,600 kg | |
| Suspension Types | Multi / Multi | |
| Shock Absorber | Double Acting | |
| Spring Size Front (mm) | 1,200 x 70 x 10t-8, 11t-1 | |
| Spring Size Rear (mm) | Main | Helper |
| | 1,250 x 70 x 10t-2 + 11t-5 | 990 x 70 x 17t-4 |

CLUTCH (MANUAL MODELS)

| | |
|-----------------|--|
| Type | Hydraulic control (air assisted), Diaphragm spring, Single dry plate, Pre-damper |
| Facing Size | 362 mm (outside diameter) x 236 mm (inside diameter) |
| Facing Material | Non-Asbestos |

WHEELS & TYRES

| | |
|--------------------|---|
| Wheel Type | Single Front, Dual Rear |
| Wheel Size | Front, Rear: 17.5 x 6.00 |
| Material | Steel |
| Tyre Size | Front: 225/75R17.5 Rear: 225/75R17.5 |
| Number of Tyres | 6 |
| Spare Tyre Carrier | Equipped |

ELECTRICAL

| | |
|--------------------------|-----------------------|
| Type | 24V Electrical System |
| Battery | 2 x MF 90Ah Batteries |
| Alternator | 24V-55A |
| Starter Type | 24V-5.0KW |
| Interior & Reading Lamps | LED |

CHASSIS FRAME

| Wheelbase Variants | MWB | LWB | ELWB |
|-----------------------|-------|-------|-------|
| Wheelbase (mm) | 3,600 | 4,050 | 4,400 |
| Overall Length (mm) | 6,370 | 6,870 | 7,370 |
| Cab to Rear Axle | 2,710 | 3,160 | 3,510 |
| Cab to End of Frame | 4,290 | 4,790 | 5,290 |
| Min. Ground Clearance | 185 | 185 | 185 |
| Min. Turning Radius | 7,000 | 7,900 | 8,600 |

PERFORMANCE

| Transmission | Manual | Automatic |
|-----------------------------------|--------|-----------|
| Application Engine | D4GB17 | D4GB17 |
| Max. Speed (km/h) | 119 | 119 |
| Max. Gradeability (tan θ) | 0.383 | 0.383 |

FUEL TANK

| | |
|----------------------|--------------------------------------|
| Material | Steel |
| Fuel Capacity | 100L (Optional: 150L for LWB & ELWB) |
| Fuel Cap | Equipped |
| AdBlue Tank Capacity | 15L |

STEERING

| | |
|------------------------|---|
| Steering Type | 4-Spoke, Ball-nut type, Tilt & Telescopic steering column |
| Steering Gear Ratio | 20.1 (Tilting Angle: -3.7 ~ 5.8°) |
| Inside Steering Angle | 44.5° |
| Outside Steering Angle | 32° |
| Telescopic Stroke (mm) | 60 mm |

CAB DETAILS

| | |
|---------------------------------|---------------------------|
| CAB Type | Super CAB |
| Seating Capacity | 3 |
| Seat Belts | Equipped |
| Sun Visor & Overhead Console | Equipped |
| Windscreen Wipers | 2-Arm Wiper & Washers |
| Rear View Mirrors | External |
| Grille Colour | Black |
| Cab Heater & Air Conditioner | Equipped |
| Floor Covering | Vinyl Type |
| Central Locking & Keyless Entry | Equipped with Immobilizer |
| Cab Storage Pockets | Equipped |
| Power Windows | Equipped |
| Reverse Alarm | Equipped |



DIMENSIONS – (mm) / WEIGHTS – (kg)

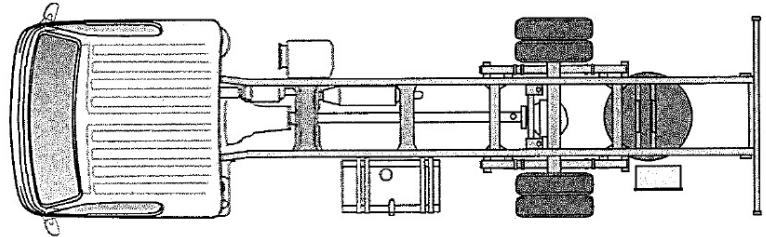
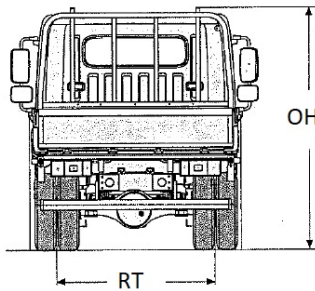
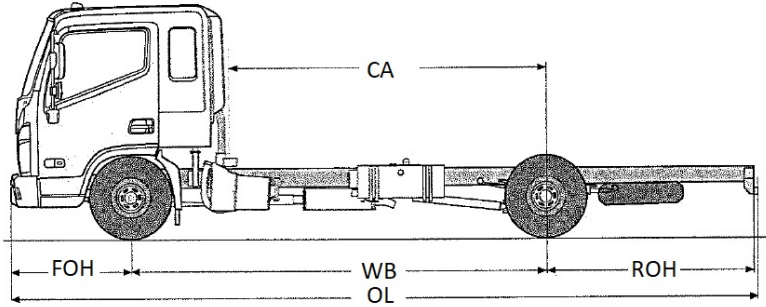
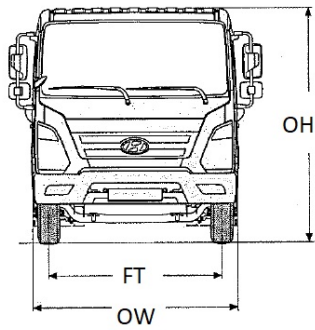

| Wheelbase | MWB | LWB | ELWB |
|----------------------|--------|--------|--------|
| WB | 3,600 | 4,050 | 4,400 |
| OL | 6,370 | 6,870 | 7,370 |
| OW | 2,020 | 2,020 | 2,020 |
| OH | 2,360 | 2,360 | 2,360 |
| CA | 2,710 | 3,160 | 3,510 |
| FOH | 1,125 | 1,125 | 1,125 |
| ROH | 1,645 | 1,695 | 1,845 |
| FT | 1,690 | 1,690 | 1,690 |
| RT | 1,650 | 1,650 | 1,650 |
| Curb Weight | 2,885 | 2,900 | 2,925 |
| Front Curb Weight | 1,935 | 1,940 | 1,990 |
| Rear Curb Weight | 950 | 960 | 935 |
| Gross Vehicle Weight | 10,300 | 10,300 | 10,300 |
| Front Axle Capacity | 3,700 | 3,700 | 3,700 |
| Rear Axle Capacity | 6,600 | 6,600 | 6,600 |

HYUNDAI MIGHTY WARRANTY

| LIGHT DUTY RANGE | AXLE CONFIGURATION | STANDARD WARRANTY (whichever comes first) | CAB CORROSION / PERFORATION |
|------------------|--------------------|--|--------------------------------|
| MIGHTY EX10 | 4 X 2 | 5 years or 300,000km | 3 years |

Battery warranty – 12 months from date of delivery

* For conditions, refer to the Hyundai Trucks Parts & Service warranty manual

Disclaimer: Hyundai Trucks Australia reserves the right to alter vehicle specifications and equipment levels without notice. Some equipment featured on the vehicle in this brochure may not be available in Australia or may be optional to the extent permitted by the law. Hyundai Trucks Australia shall not be liable to any person as a result of reliance on the content of this document.

Please consult your Hyundai Truck Dealer for the latest specifications, equipment levels, options, prices, colours and vehicle availability.

Note: Information in this brochure is current as at 01/08/2025

You are never alone on the road in a Hyundai Mighty series truck.

When you are covered by Hyundai's 24/7 nationwide truck roadside assist, you will never find yourself stranded.



AVAILABLE FACTORY BODY OPTIONS

| FLAT DECK | Length x Width | |
|--------------------|----------------------------|-----------------------------|
| Deck Area | (LWB) 5,100mm x 2,450mm | (ELWB) 6,000mm x 2,450mm |
| Est. Weight | 889kg | 986kg |



| PANTECH | Length x Width x Height | |
|--------------------|--------------------------------------|--|
| Dimensions | (LWB) 5,000mm x 2,390mm x 1,900mm | |
| Est. Weight | 1,000kg | |

***Available options** – Side Door, E-track, Tie Rails, Rear Roller Door, Triple Rear Door
(Please note the internal dimensions may differ depending on the side door option)



| CHILLER | Length x Width x Height | |
|--------------------|--------------------------------------|--|
| Dimensions | (LWB) 5,000mm x 2,300mm x 1,900mm | |
| Est. Weight | 1,100kg | |

Operating Temperature – 0 to 4°C

***Available options** – Side Door, E-track, Tie Rails, Rear Roller Door, Triple Rear Door
(Please note the internal dimensions may differ depending on the side door option)



| FREEZER | Length x Width x Height | |
|--------------------|--------------------------------------|--|
| Dimensions | (LWB) 5,000mm x 2,390mm x 1,900mm | |
| Est. Weight | 1,300kg | |

Operating Temperature – down to -17°C

*Based on actual testing at 32°C
 (ambient temperature)*

***Available options** – Side Door, E-track, Tie Rails, Rear Roller Door, Triple Rear Door
(Please note the internal dimensions may differ depending on the side door option)



Factory body warranty - 12 months from date of delivery